

TOP VIEW

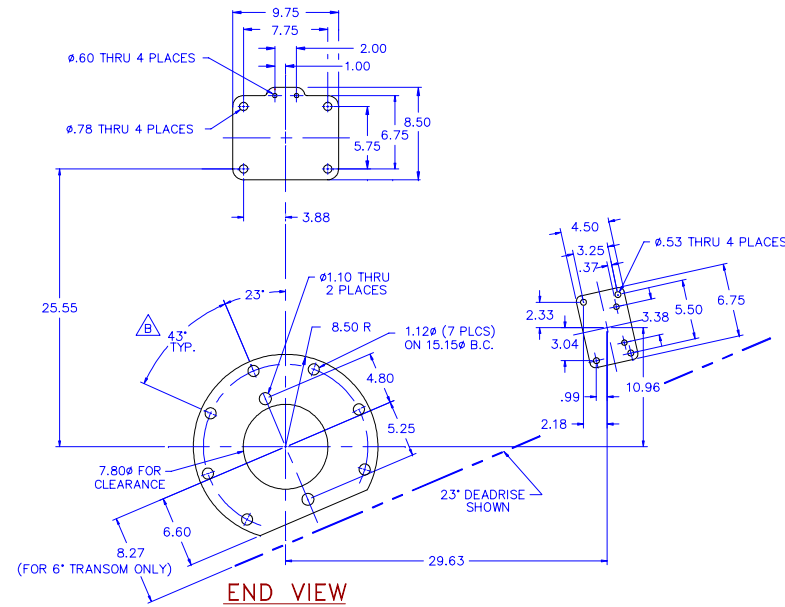

END VIEW

(DIMENSIONS ARE PARALLEL WITH TRANSOM)

- NOTES:
1. THIS DRAWING IS TO BE USED AS A GUIDE ONLY. PLEASE REFER TO THE TWIN DISC INSTALLATION MANUAL FOR INSTALLING THE DRIVE AND CYLINDERS.
  2. TRANSOM ANGLE FOR ASD UNITS TO BE 6 DEGREES TO VERTICAL, PLUS OR MINUS 1 DEGREE, AS SHOWN IN THE SIDE VIEW. A MOUNTING WEDGE IS REQUIRED FOR TRANSOM ANGLES OTHER THAN 6 DEGREES.
  3. BACKING PLATES OF SAME APPROXIMATE DIMENSIONS AS SHOWN FOR EQUIPMENT FOOTPRINT ARE SUPPLIED. ADEQUATE CLEARANCE INSIDE VESSEL TRANSOM SHOULD BE PROVIDED.
  4. DRILL ALL HOLES PERPENDICULAR TO TRANSOM.

HUB: METRIC INTERNAL INVOLUTE SPLINE		
SPLINE TYPE	DIN 5480	
REF. DIAMETER	db	72
PRESSURE ANGLE	30	
MODULE	m	2.5
NUMBER OF TEETH	Z	27
PITCH DIA.	d	67.5
BASE DIA.	db	58.457
TOLERANCE	9H	
MEASURED BETWEEN Dm=4.5 PINS	BASIC	62.434
	MAX.	62.576
	MIN.	62.487

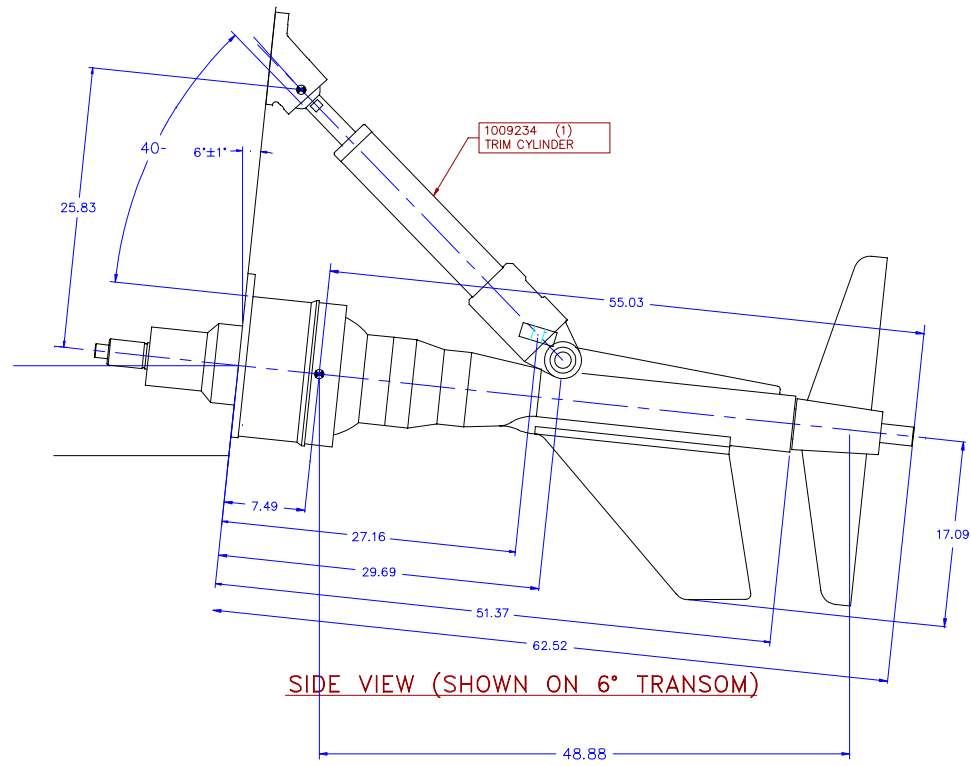

SIDE VIEW (SHOWN ON 6° TRANSOM)

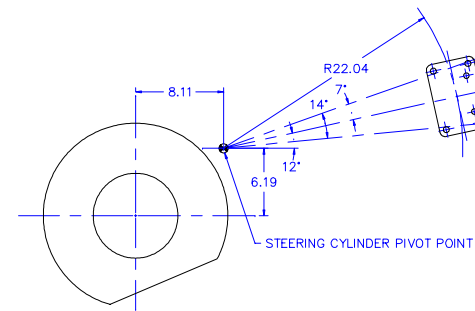

OPTIONAL RANGE FOR STEERING CYLINDER LOCATION

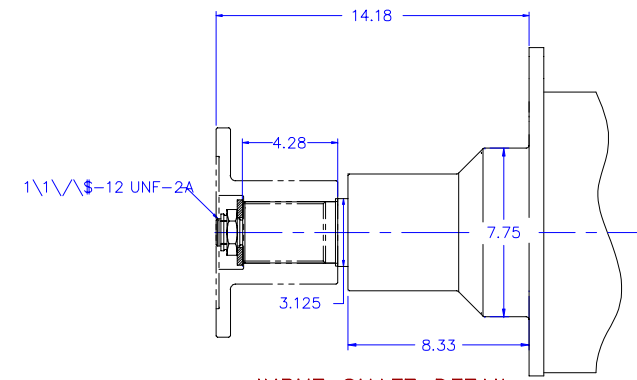

INPUT SHAFT DETAIL

SCALE 2:1

REV	ZONE	CH. NO.	DATE	REV	ZONE	CH. NO.	DATE

NOTICE: THIS PRINT CONTAINS PROPRIETARY INFORMATION AND IS NOT TO BE USED IN ANY MANNER DETRIMENTAL TO THE INTERESTS OF TWIN DISC, INCORPORATED RACINE, WI 53403 - USA THIS NOTICE IS NOT INTENDED TO NULLIFY OR LIMIT RIGHTS GRANTED TO THE U.S. GOVERNMENT OR OTHERS BY CONTRACT.

MATERIAL	WEIGHT	UNLESS OTHERWISE SPECIFIED
HEAT TREAT	FIRST USE	MACHINED DIMENSIONS
SURFACE TREATMENT	ASSY. MODEL ASD-12L	XX ±0.030
	NAME	XXX ±0.010
		XXX ±0.005
		ALL ANGULAR TOLERANCES ±1°
		GEOMETRIC TOLERANCING PER ANSI Y14.5M-1982

DATE	9-19-97
SCALE	1/8=1"
DRN:	TBM
CHK:	FN
APPD:	FN

THIRD ANGLE PROJECTION

SIMILAR TO 1006974

REF. 002374

**TWIN DISC** INCORPORATED  
RACINE, WI 53403 - USA

**1017592**

INSTALLATION

SHEET 1 OF 1 REV